

Effio™

Over 650TV-Line Camera DSP Series



"Effio" Series Lineup

"Effio" Series

	"Effio"	NEW! "Effio-E"
Product Name	CXD4112AGG Wide dynamic range model for 960H CCD	CXD4127GG Entry-level model for 960H CCD
System Configuration	CCD: 760H, 960H CCDs AFE: CXD4813GG DSP: "Effio" (CXD4112AGG) LPDDR	CCD: 510H, 760H, 960H CCDs AFE: CXD4816GG DSP: "Effio-E" (CXD4127GG) <details>
Key Features	<ul style="list-style-type: none"> ·Horizontal resolution of over 650 TVL ·Wide dynamic range ·2D and 3D noise reduction ·OSD ·Motion detection ·DC/Video servo ·Digital zoom ·Slow shutter ·Face detection ·Dual analog and digital outputs ·Synchronization: LL, VSL, VBSLHP/HR, HRVR 	<ul style="list-style-type: none"> ·Horizontal resolution of over 650 TVL ·ATR (Adaptive Tone Reproduction) ·2D noise reduction ·Preset OSD menu (8 languages) ·Motion detection ·DC/Video servo ·Dual analog and digital outputs ·HLC (High light compensation) ·Low power consumption <details>

"Effio-E" System Block Diagram and Main Specification

System Configuration

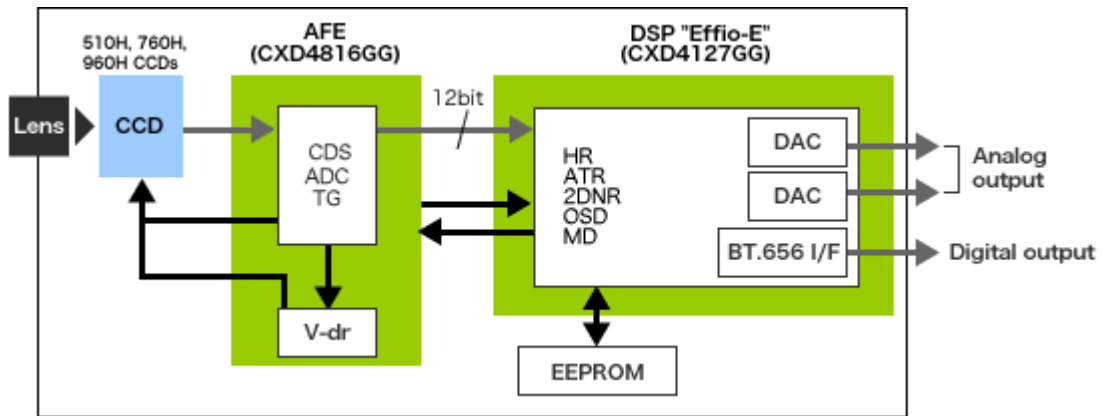

Specifications

Item	"Effio-E" system	
Supported CCDs	510H, 760H, 960H CCDs	
System Configuration	2 chips (DSP/AFE)	
Main Functions	Horizontal Resolution	Over 650 TVL
	ATR	Yes
	Noise Reduction	2D-NR
	Day & Night	Yes
	Privacy Mask	8 masks
	HLC	Yes
	AFD	Yes
	Motion Detection	Yes
	OSD Menu	8 languages
	White Pixel Detection and Compensation	Static and Dynamic
	Automatic Adjustment of Mechanical Iris	Yes
	External Synchronization	Line-Lock
	Outputs	Analog Output

	Digital Output	-ITU-R BT.656 Compliant (27MHz) -CCD image size (CCD drive frequency)
	Dual Analog and Digital Outputs	Yes
Power Supply Voltages		CXD4127GG: 3.3V, 1.2V CXD4816GG: 3.3V, VH, VL
Packages		CXD4127GG: LFBGA 97Pin CXD4816GG: LFBGA 80Pin

960H CCD Image Sensor

Product Name	ICX662AKA ICX663AKA	ICX668AKA ICX669AKA	NEW! ICX672AK ICX673AK
	"Super HAD CCD II "	"Super HAD CCD II "	"EXview HAD CCD II "
Image Size	Type 1/3	Type 1/4	Type 1/3
Pixels	480k 570k	480k 570k	480k 570k
Effective Pixels	976(H) x 494(V) 976(H) x 582(V)	976(H) x 494(V) 976(H) x 582(V)	976(H) x 494(V) 976(H) x 582(V)
Unit Cell Size [μm]	5.0(H) x 7.4(V) 5.0(H) x 6.25(V)	3.75(H) x 5.56(V) 3.75(H) x 4.69(V)	5.0(H) x 7.4(V) 5.0(H) x 6.25(V)
Sensitivity [mV] (F5.6)	1600	1400 1350	2450 2400
Saturation Signal [mV]	800	600 540	1400
Smear [dB] (F5.6)	-105	-105	-110
Supply Voltage [V]	+15/-7.5 (typ.)	+15/-7.5 (typ.)	+15/-7.0 (typ.)

H Transfer Voltage [V]	3.3 (typ.)	3.3 (typ.)	3.3 (typ.)
------------------------	------------	------------	------------

*CCD = CCD image sensor

Super HAD CCD II™

*"Super HAD CCD II" is a trademark of Sony Corporation.

The "Super HAD CCD II" is a version of Sony's high performance CCD HAD (Hole-Accumulation Diode) sensor with realized sensitivity (typical) of 1000mV or more per $1\mu\text{m}^2$ (Color: F5.6/ BW: F8 in 1 s accumulation equivalent.)

EXview HAD CCD II™

*"EXview HAD CCD II" is a trademark of Sony Corporation. The "EXview HAD CCD II" is a CCD image sensor that realizes sensitivity (typical) of 1000mV or more per $1\mu\text{m}^2$ (Color: F5.6/ BW: F8 in 1 s accumulation equivalent) and improves light efficiency by including near infrared light region as a basic structure of Sony's "EXview HAD CCD".